



Royal Danish Yachtclub
Tuborg Havnepark 15, DK-2900 Hellerup
<http://www.kdy.dk>
+45 33 14 87 87
kdy@kdy.dk

VINTAGE YACHTING GAMES 2018

SAILING INSTRUCTION (VERSION 1.1)





TABLE OF CONTENTS

IMPORTANT INFORMATION	3
SAILING INSTRUCTIONS	4
1. VENUE	4
2. RULES.....	4
3. ADDITIONAL IDENTIFICATION AND ADVERTISING	4
4. CAMERAS AND ELECTRONIC EQUIPMENT	4
5. NOTICES TO COMPETITORS	4
6. CHANGES TO SAILING INSTRUCTIONS.....	5
7. SIGNALS MADE ASHORE	5
8. FORMAT OF RACING	5
9. SCHEDULE OF RACES (WARNING SIGNALS)	5
10. EVENT FLAGS	5
11. COURSE AREAS, COURSES AND MARKS	5
12. WIND RANGE	7
13. THE START	7
14. CHANGE OF THE NEXT LEG OF THE COURSE.....	7
15. THE FINISH.....	7
16. TIME LIMITS	7
17. PROTESTS AND REQUESTS FOR REDRESS	7
18. SCORING	8
19. SAFETY REGULATIONS	8
20. REPLACEMENT OF CREW	8
21. PROTEST COMMITTEE TV AND PRESS BOATS	9
22. OFFICIAL BOATS	9
23. SUPPORT BOATS	9
24. REGISTRATION	9
25. MEASUREMENT	9
26. MISCELLANEOUS.....	9
27. PRIZES OVERVIEW.....	90
28. LIABILITY AND INSURANCE.....	90
APPENDIX A: AUSTRIAN POINT SYSTEM (OLYMPIC SCORING SYSTEM 1948 – 1964).....	111



Royal Danish Yachtclub
Tuborg Havnepark 15, DK-2900 Hellerup
<http://www.kdy.dk>
+45 33 14 87 87
kdy@kdy.dk

IMPORTANT INFORMATION

Hellerup Marina, Hellerup Sailing Club

Address: Paul Elvstrøms Plads 1

City: 2900 Hellerup

Phone: +45 39628803

Contact: Ann Filippa Madsen, Regatta manager, Hellerup Sailing Club DEN

e-mail: regatta@hellerupsejlkлуб.dk

Event manager

LARS IVE, DK

Phone: +45 40137007

e-mail: lai@kdy.dk

Liaison officer Vintage Yachting Games Organization

RUDY DEN OUTER/THIES BOSCH NED

Phone: +31 624218063/+31 653727343

rudy@vintageyachtinggames.org

Principal Race Officer

PETER STEPHENSEN LÜBECK (IRO) DEN

Chairman of the Protest Committee

JAN HELGE MADSEN (NJ) DEN

Members of the Protest Committee

fl GUNNER JUHL-NYHOLM (NJ) DEN

fl PETER WARD (J) DK

FOR EMERGENCY DIAL: 112





SAILING INSTRUCTIONS

1. VENUE

- 1.1 The 2018 Vintage Yachting Games will be held from 16 till 22 September 2018 at Øresund East of Hellerup Harbour.

2. RULES

- 2.1 The official language of the Vintage Yachting Games will be English
- 2.2 The Vintage Yachting Games 2018 are governed by the rules defined in The Racing Rules of Sailing 2017 - 2020.
- 2.3 The following prescription of the Danish national authority will apply: Danish legislation requires every boat to be equipped with personal buoyancy for the number of persons on board at any time.
- 2.4 Vintage Yachting Games Rules
- 2.5 The Notice of Race
- 2.6 This Sailing Instructions
- 2.7 The Class Rules of the Vintage Yachting Classes
- 2.8 Rule RRS 44.2 will **NOT** be modified.
- 2.9 Rule RRS 44.3 will **NOT** apply.
- 2.10 In the event of a conflict between the different rules the sequence of the above rules, as allowed by the RRS 2017 – 2020, will be final.
- 2.11 Event specific rules:

Event	Specific rules
	<p>fi The International 12 will race with wooden clinker built according to the original design, and shaped, rigged and fitted accordingly. Vintage dinghies will generally be accepted, round wood should be solid, sails should be fixed to boom and lug such that no profitable in-race adjustment is possible. There should be no gear for profitable in-race adjustability of the mast foot. A boom marline is allowed but not required. On individual cases the International 12 class organization shall decide with or without request.</p>
	<p>fi No specific rules</p>
	<p>fi While racing the number of persons on board a Soling shall be 3 at all times</p> <p>fi As permitted by RRS 86.1 (c), RRS 42.3 (c) is altered to:</p> <p>fi Except on a beat to windward, when surfing (rapidly accelerating down the leeward side of a wave) or planing is possible, the crew may pull the sheet controlling any sail in order to initiate surfing or planing, but not more than twice for each wave or gust of wind. In addition, pumping of the spinnaker guy is permitted at all times without restriction. In this part of the Rule pumping of the spinnaker guy means repeatedly trimming and releasing the guy by any means. Moving the body as necessary to pump the guy is permitted and shall not be considered to be ooching (see RRS 42.2 (c)), nor shall any rolling of the boat caused by such necessary movements be considered rocking (see RRS 42.2 (b)).</p> <p>fi A maximum of 1 mast, 1 boom, 1 spinnaker pole, 1 main, 2 Jibs and 2 spinnakers can be registered for use at the Vintage Yachting Games</p>

3. ADDITIONAL IDENTIFICATION AND ADVERTISING

- 3.1 Boats will be required to display advertising chosen and supplied by the organizing authority in accordance with World Sailing Regulation 20.

4. CAMERAS AND ELECTRONIC EQUIPMENT

- 4.1 Boats may be required to carry cameras, sound equipment or positioning equipment as specified by the organizing authority.

5. NOTICES TO COMPETITORS

- 5.1 Notices to competitors will be posted on the official notice boards located in the hall of Hellerup Sailing Club.



6. CHANGES TO SAILING INSTRUCTIONS

- 6.1 Any change to the sailing instructions will be posted no later than 3 hours before the first scheduled warning signal on that day, except that any change to the schedule of races will be posted by 20.00 on the day before it will take effect.
- 6.2 After postponement ashore, reassignment of classes for racing will be posted before flag AP is lowered; see instruction 7.2.
- 6.3 Each change in the sailing instructions must be counter signed by the liaison officer of the Vintage Yachting Games Organization before posting.

7. SIGNALS MADE ASHORE

- 7.1 The signals made ashore will be from the main flagpoles in Hellerup sailing Club.
- 7.2 When flag AP is displayed ashore, '1 minute' in RRS: RACE SIGNALS AP, is replaced with: 'not less than 60 minutes'.

8. FORMAT OF RACING

- 8.1 For each event in the Vintage Yachting Games eight (8) races are scheduled.

9. SCHEDULE OF RACES (WARNING SIGNALS)



- 9.1 No more than 2 races per event will be held on the same day.
- 9.2 On Sept 22nd no warning signal will be made after 15.30.
- 9.3 When, for an event, 2 races will be held on the same day, the warning signal for the second race will be made as soon as practicable. After a long postponement, to alert boats that a race or sequence of races will begin soon, an orange flag will be displayed (with one sound) for at least five minutes before a warning signal is displayed.
- 9.4 A scheduled race not being sailed on a day may be rescheduled to another day.
- 9.5 Initial schedule of races (Warning signal first race of the day):

Event	Sept 18th	Sept 19th	Sept 20th	Sept 21th	Sept 22th
	14:00 Race 1	13:00 Race 2 & 3	13:00 Race 4 & 5	13:00 Race 6 & 7	11:00 Race 8
	14:15 Race 1	13:15 Race 2 & 3	13:15 Race 4 & 5	13:15 Race 6 & 7	11:15 Race 8
	14:25 Race 1	13:25 Race 2 & 3	13:25 Race 4 & 5	13:25 Race 6 & 7	11:25 Race 8

- 9.6 It shall be the sole responsibility of a boat to ensure herself of her correct scheduling and starting times. Failure to do so shall not be grounds for redress.
- 9.7 The VIP race followed by prize giving ceremony followed by the closing ceremony of the Vintage Yachting Games 2018 is scheduled for 15:00.

10. EVENT FLAGS

- 10.1 The following event flags will be used:



Event	12' Dinghy	O-Jolle	Soling
FLAG			

11. COURSE AREAS, COURSES AND MARKS

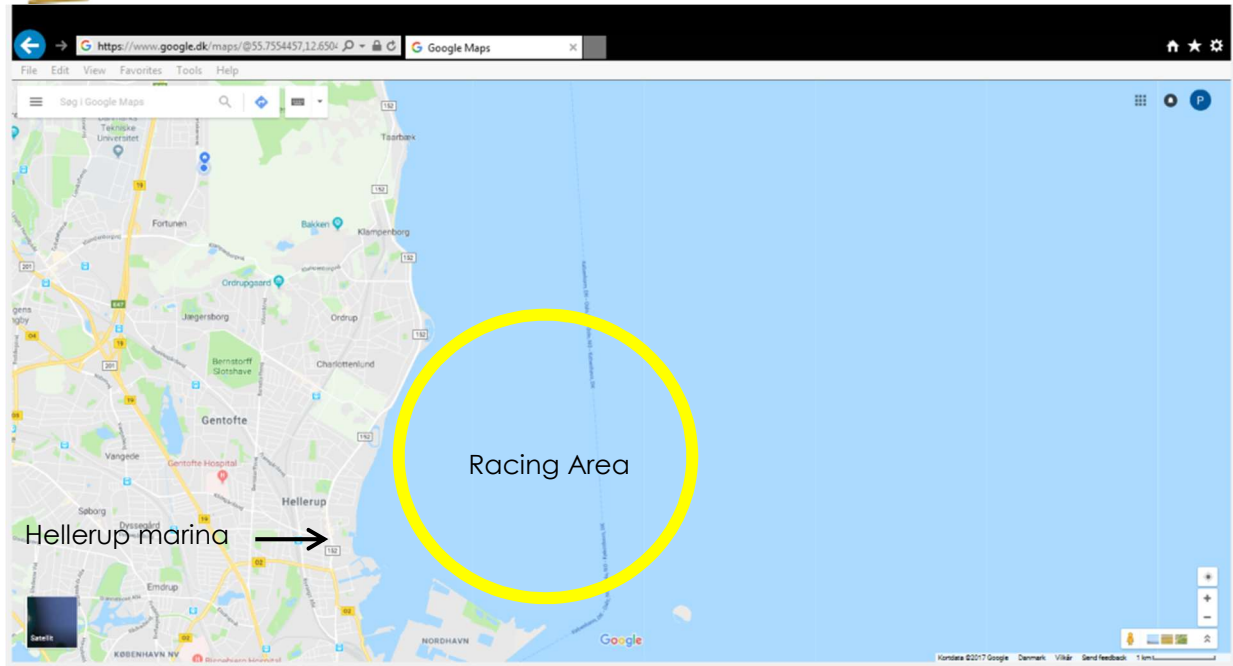
- 11.1 Course area (approximately)



11.2 Courses

Course LA	Windward/Leeward with Offset
LA2 	Mark Rounding Order Start – 1 – 1a – 3S/3P – 1 – 1a – 3P – Finish
LA2 	Start – 2 – 2a – 3S/3P – 2 – 2a – 3P – Finish



11.3 The color of the marks:

Course 1: mark 1- yellow inflatable mark, mark 2, 3S and 3B – orange inflatable marks, mark 1a and 2a– buoy with a BG flag

www.vintageyachtinggames.org



Courses and classes

CLASS	LENGTH 1 ST BEAT	COURSE
	0.5 – 1.2 nm	
	0.5 – 1.2 nm	or
	0.9 – 1.8 nm	or

11.4 No later than the warning signal, the starting vessel will display the approximate compass bearing, approximate length of the first leg and the course numeral.

11.5 Courses will not be shortened (by code flag "S").

12. WIND RANGE

12.1 As guideline the organization tries to sail the events within a wind range of 5 to 27kn.

13. THE START

13.1 Races will be started by using RRS 26.

13.2 The starting line will be between an orange flag on the race committee vessel at the starboard end and a staff displaying an orange flag on the race committee vessel at the port end.

13.3 Boats whose warning signal has not been made shall avoid the starting area.

13.4 A boat starting later than four minutes after her starting signal will be scored Did Not Start (DNS) without a hearing. This changes RRS A4 and A5.

13.5 After a postponement, the race committee may change the order of the classes in the racing schedule.

14. CHANGE OF THE NEXT LEG OF THE COURSE

14.1 To change the next leg of the course, the race committee will move the original mark to a new position (or move the finishing line).

15. THE FINISH

15.1 The finishing line will be between a blue flag on the finishing vessel and a staff buoy displaying a blue flag.

16. TIME LIMITS

16.1 The time limit to the first mark for the first boat in each event is 45 minutes. If the first boat in an event fails to complete the first leg in time the race will be abandoned.

16.2 The time limit for each race is 2.5 hours for the first boat in each event. If the first boat in an event fails to complete the race within this time limit the race will be abandoned.

16.3 Boats failing to complete the race, within 20 minutes after the first boat sailing the course and finished, will score DNF.

17. PROTESTS AND REQUESTS FOR REDRESS

17.1 A Protest Committee will be appointed.

17.2 Protest forms are available at the race offices. Protests and requests for redress or reopening shall be delivered there within the appropriate time limit.

17.3 For each fleet, the protest time limit is 90 minutes after the last boat has finished the last race of the day, or 90 minutes after the last signal of postponed or abandoned of the last race of the day.

17.4 Notices will be posted within 30 minutes of the protest time limit of the fleet finishing last in the day of the protest time limit to inform competitors of hearings in which they are parties or named as witnesses. Hearings will be held in the protest room, beginning at the time posted.

17.5 Notices of protests by the race committee or protest committee will be posted to inform boats under RRS 61.1(b).

17.6 Breaches of Sailing Instructions 3, 3.1, 12 13.3, 17.4, 19, 23, 24 and as well as the rules 4 and 6 of the Notice of Race will not be grounds for a protest by a boat. This changes



rule 60.1 (a). Penalties for these breaches may be less than disqualification if the protest committee so decides.

- 17.7 Penalties for infringement of class rules may be less than disqualification if the protest committee so decides.
- 17.8 The scoring abbreviation for a discretionary penalty imposed under instructions 17.6 and 17.7 will be DPI.

18. SCORING

- 18.1 The events
 - 18.1.1 The Bonus Point scoring system of RRS Appendix A will apply.
 - 18.1.2 For all events eight (8) races are scheduled. Four (4) races shall be completed to constitute an event in the Vintage Yachting Games.
 - 18.1.3 When fewer than five races have been completed in an event a boat's event score will be the total of her race scores.
 - 18.1.4 When five (5) or more races have been completed in an event, a boat's event score will be the total of her race scores excluding her worst score.
 - 18.1.5 To request correction of an alleged error in posted race or series results, a boat shall complete a scoring enquiry form available at the race office
- 18.2 The Country Trophy
 - 18.2.1 The final results of an event will be taken as base for the score for the Country Trophy. Than the Austrian point system will be applied per class.
 - 18.2.2 The position of the best performing boat per event per country will determine the score of that country.
 - 18.2.3 If a country is not represented in an event that country will score a Did Not Compete (DNC) in that event.
 - 18.2.4 The winning country is that country with the highest combined score over all events.
- 18.3 VIP race
 - 18.3.1 The responsible person of the first three boats in each event are invited to compete in the VIP race
 - 18.3.2 The VIP race will be held in supplied 12' dinghies that will be appointed by a draw. Participants from the 12' dinghy class will not helm their own boat
 - 18.3.3 Sailing instruction for this race will be handed out just before the start.

19. SAFETY REGULATIONS

- 19.1 A boat leaving the racing area before the end of a race shall notify a race committee boat before leaving the racing area or, when that is impossible, the regatta office, immediately after arrival in the harbor.
- 19.2 Boats not leaving the harbor for a day's race shall inform the regatta office prior to the start.
- 19.3 If any one of the signals Flag 'AP over A' or 'AP over H' or 'N over H' is made on a race committee boat, all boats of the classes concerned shall return to harbor immediately!
- 19.4 While afloat it is strongly recommended to wear adequate personal buoyancy under all circumstances.

20. REPLACEMENT OF CREW

- 20.1 For single-handed classes only: Crew substitution of registered sailors is not permitted.
- 20.2 Replacement of crew will not be allowed without prior written approval of the protest committee.

21. PROTEST COMMITTEE TV AND PRESS BOATS

- 21.1 Action or NO action taken by protest committee, TV and Press boats or helicopters shall not be grounds for requesting redress by a boat. This alters RRS 60.1 (b).

22. OFFICIAL BOATS

- 22.1 Official boats will be marked as follows:
 - 22.1.1 Committee boats will fly KDY or HS flags.



23. SUPPORT BOATS

- 23.1 Team leaders, coaches and other support personnel shall stay outside areas where boats are racing from the time of the preparatory signal for the first class to start until all boats have finished or the race committee signals a postponement, general recall or abandonment.
- 23.2 All support personnel shall register at the registration offices for the class(es) concerned.

24. REGISTRATION

- 24.1 Registration will take place Sept 16th and Sept 17th between 09:00 and 18:00 for all classes
- 24.2 The responsible person (must present at the registration the following documents:
- 24.2.1 Valid measurement form
- 24.2.2 Valid membership card of the respective International Class Organization for each member of the crew.

25. MISCELLANEOUS

- 25.1 Team/Coach/Support boats shall carry their national identification letters or National flag during the Vintage Yachting Games at ALL times when afloat
- 25.2 When docked/hailed out boats and Team/Coach/Support boats shall be kept in their assigned places
- 25.3 Unless permission is given by the jury, keelboats must be afloat after Sept 17th, 18:00
- 25.4 Keelboats shall **NOT** be hauled-out during the Vintage Yachting Games except with and according to the terms of prior written permission of the protest committee
- 25.5 Underwater breathing apparatus and plastic pools or their equivalent shall not be used around keelboats between the preparatory signal of the first race and the end of the Vintage Yachting Games except with and according to the terms of prior written permission of the protest committee
- 25.6 A boat shall neither make radio transmissions while racing nor receive radio communications **NOT** available to all boats. This restriction also applies to mobile telephones, VHF Radio and GPS systems. If on board these systems must be switched off (**NOT** on "standby" or "flightmode" or equivalent) while afloat.

26. PRIZES OVERVIEW

- fi At least the following prizes will be awarded:
 - fi Daily prizes
 - fi Overall prizes
 - fi Perpetual prizes
 - fi Country trophy
 - fi VIP prize
- fi Daily prizes (for the winning boat in each race in each event)
- fi Overall prizes (for all boats with overall ranking 1 – 3):
 - fi The right to fly the Vintage Yachting Games logo in respectively Gold, Silver or Bronze in the mainsail until the next Vintage Yachting Games.
 - fi A medal will be awarded to each sailor
- fi Perpetual prizes:
 - fi All classes: Vintage Yachting Games Trophy
 - fi VIP: Poul Richard Hoy Jensen Trophy
 - fi Menno Meyer Country trophy: For the best performing country (Perpetual)

27. LIABILITY AND INSURANCE

- 27.1 A boat is entirely responsible for her own safety, whether afloat or ashore and nothing whether in the Notice of Race or Sailing Instructions or anywhere else, reduces this responsibility.
- 27.2 It is for the boat to decide whether she is fit to sail in the conditions in which she will find herself. By going to sea, the boat confirms that she is fit for those conditions and her crew is competent to sail and compete in them. RRS 4.
- 27.3 The boat is required to hold adequate insurance and in particular to hold insurance against third party claims in the sum of at least € 1,500,000.-



- 27.4 Nothing done by the organizers can reduce the responsibility of the boat nor will it make the organizers responsible for any loss, damage, death or personal injury, however it may have occurred as a result of the boat taking part in the racing. The organizers encompass everyone helping to run the racing and the event and include the organizing authority, the race committee, the race officer, patrol boats and beach masters.
- 27.5 The provision of patrol boats does not relieve the boat of her responsibilities.
- 27.6 The fact that the race committee conducts inspections of the boat does not reduce the responsibilities of the boat set out in this paragraph.
- 27.7 Competitors are also advised to arrange their own personal accident insurance.



APPENDIX A: AUSTRIAN POINT SYSTEM (OLYMPIC SCORING SYSTEM 1948 – 1964)

$$\text{Points} = 101 + (1000 \log E - 1000 \log R)$$

Rank (R)	Number of entries (E)																								
	2	3	4	5	6	7	8	9	10	11	12	13	14	15	16	17	18	19	20	21	22	23	24	25	
1	402	578	703	800	879	946	1004	1055	1101	1142	1180	1215	1247	1277	1305	1331	1356	1380	1402	1423	1443	1463	1481	1499	
2	101	277	402	499	578	645	703	754	800	841	879	914	946	976	1004	1030	1055	1079	1101	1122	1142	1162	1180	1198	
3		101	226	323	402	469	527	578	624	665	703	738	770	800	828	854	879	903	925	946	966	986	1004	1022	
4			101	198	277	344	402	453	499	540	578	613	645	675	703	729	754	778	800	821	841	861	879	897	
5				101	180	247	305	356	402	443	481	516	548	578	606	632	657	681	703	724	744	764	782	800	
6					101	168	226	277	323	364	402	437	469	499	527	553	578	602	624	645	665	685	703	721	
7						101	159	210	256	297	335	370	402	432	460	486	511	535	557	578	598	618	636	654	
8							101	152	198	239	277	312	344	374	402	428	453	477	499	520	540	560	578	596	
9								101	147	188	226	261	293	323	351	377	402	426	448	469	489	508	527	545	
10									101	142	180	215	247	277	305	331	356	380	402	423	443	463	481	499	
11										101	139	174	206	236	264	290	315	338	361	382	402	421	440	458	
12											101	136	168	198	226	252	277	301	323	344	364	384	402	420	
13												101	133	163	191	218	242	266	288	309	329	349	367	385	
14													101	131	159	185	210	234	256	277	297	317	335	353	
15														101	129	155	180	204	226	247	267	287	305	323	
16															101	127	152	176	198	219	239	259	277	295	
17																101	126	149	172	193	213	232	251	268	
18																	101	124	147	168	188	207	226	244	
19																		101	123	144	165	184	202	220	
20																			101	122	142	162	180	198	
21																				101	121	141	159	177	
22																					101	120	139	157	
23																						101	119	137	
24																							101	119	
25																								101	
DNF	101	101	101	101	101	101	101	101	101	101	101	101	101	101	101	101	101	101	101	101	101	101	101	101	
DNC	0	0	0	0	0	0	0	0	0	0	0	0	0	0	0	0	0	0	0	0	0	0	0	0	
DND	0	0	0	0	0	0	0	0	0	0	0	0	0	0	0	0	0	0	0	0	0	0	0	0	
DNS	0	0	0	0	0	0	0	0	0	0	0	0	0	0	0	0	0	0	0	0	0	0	0	0	
DSQ	0	0	0	0	0	0	0	0	0	0	0	0	0	0	0	0	0	0	0	0	0	0	0	0	
OCS	0	0	0	0	0	0	0	0	0	0	0	0	0	0	0	0	0	0	0	0	0	0	0	0	